

BOCA DE LOBO DE GRELHA

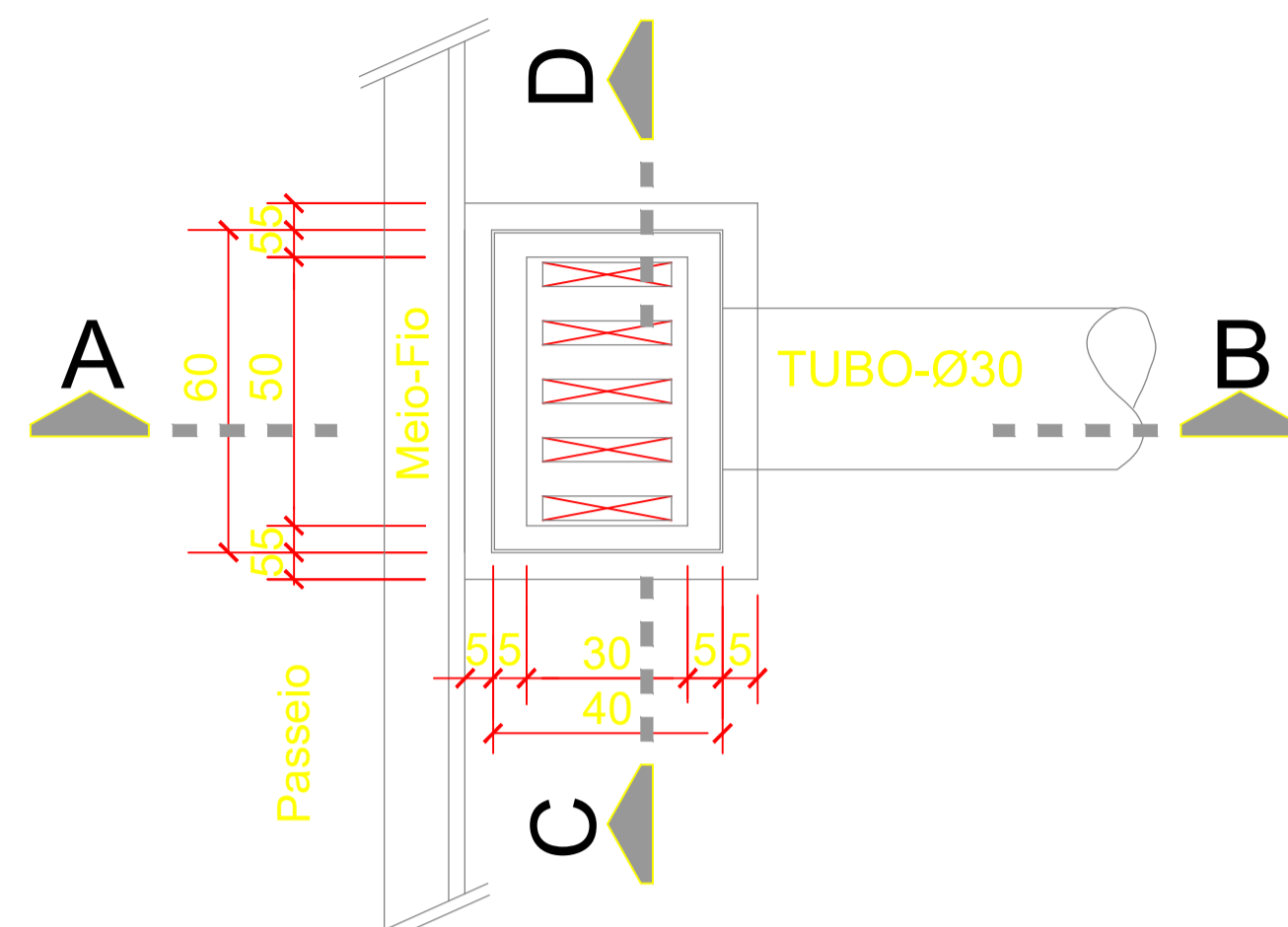

PLANTA BAIXA
ETAPA - 1

DETALHE DO ASSENTAMENTO DOS TUBOS DE CONCRETO

Sem Escala

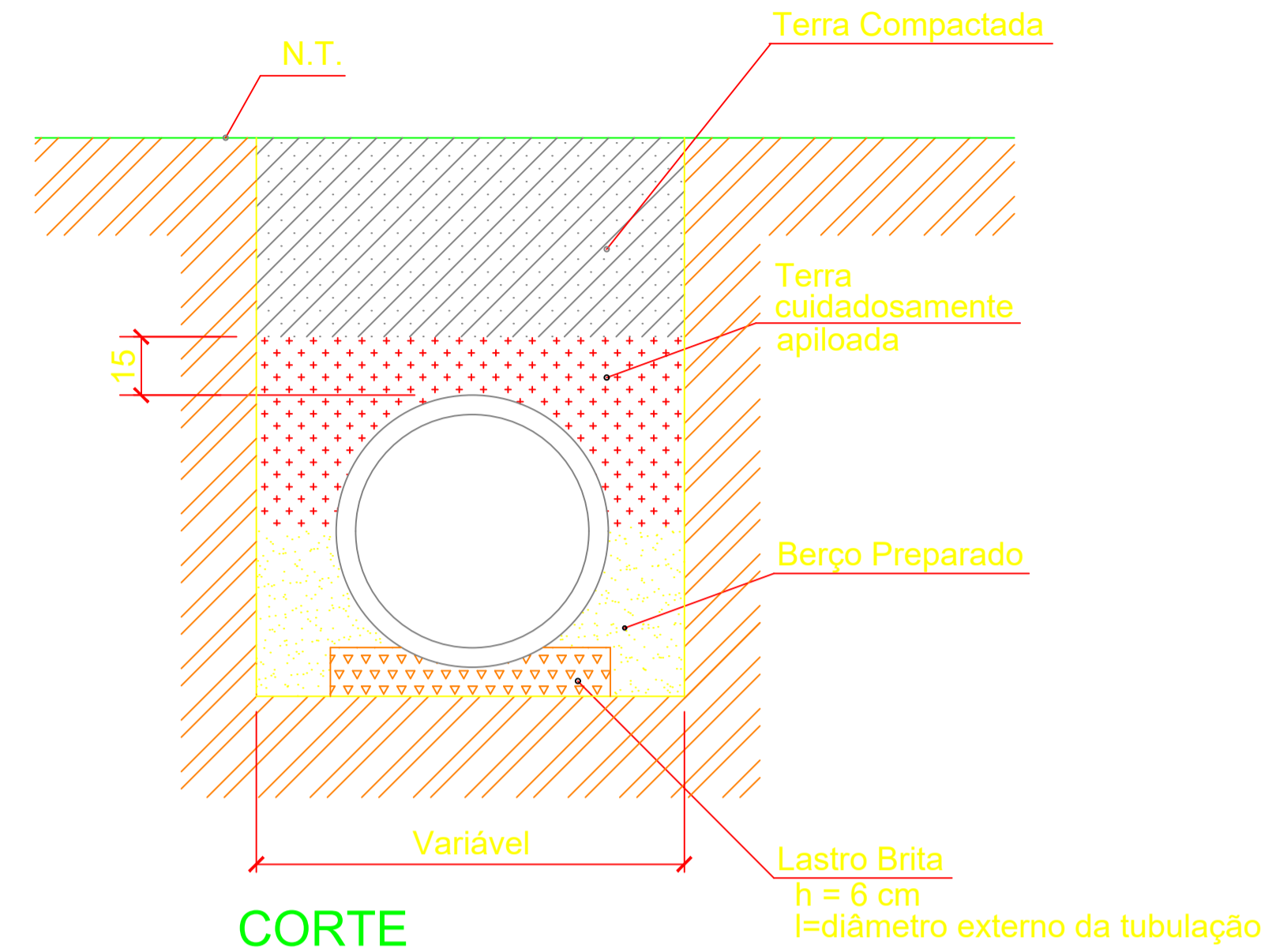

CORTE

ETAPA - 2

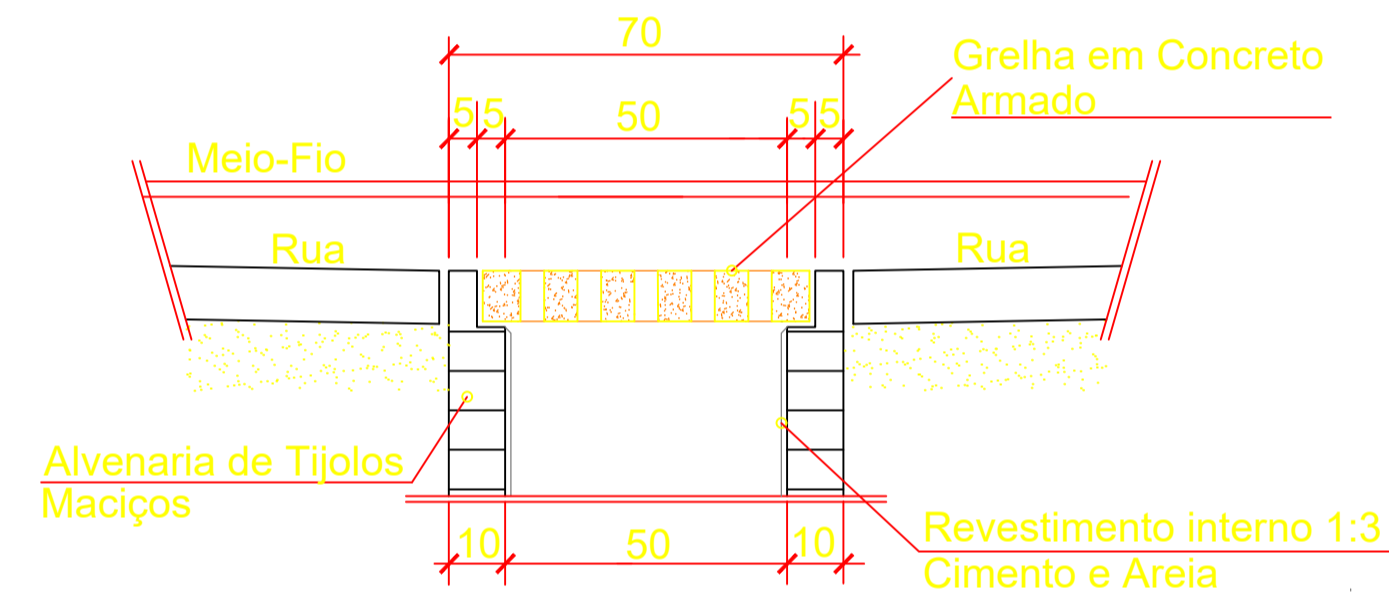

CORTE CD

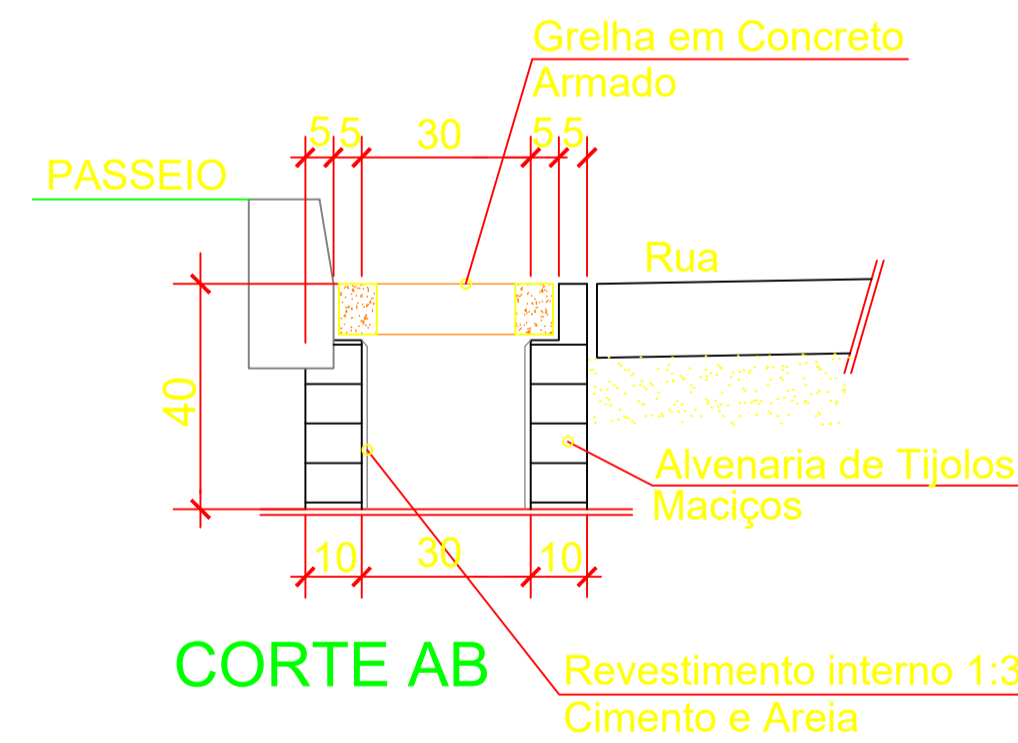

CORTE AB

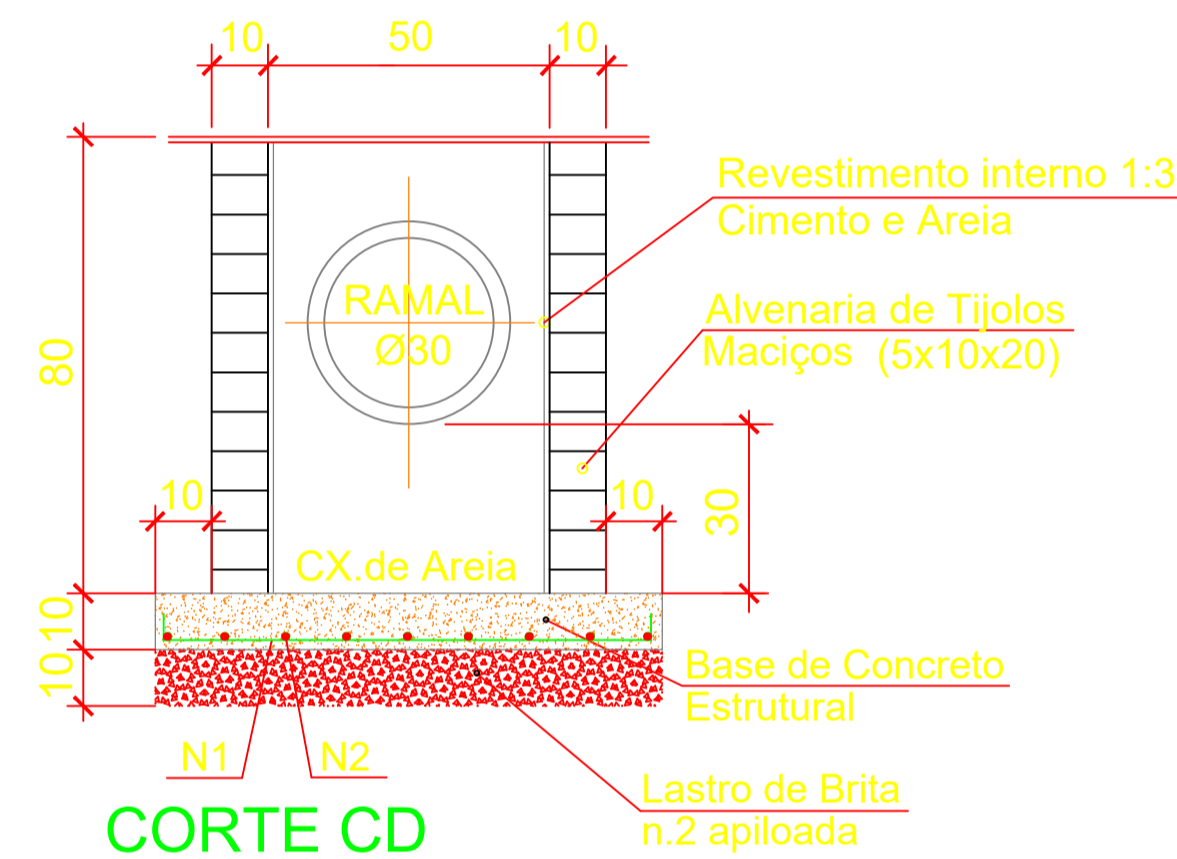

CORTE CD

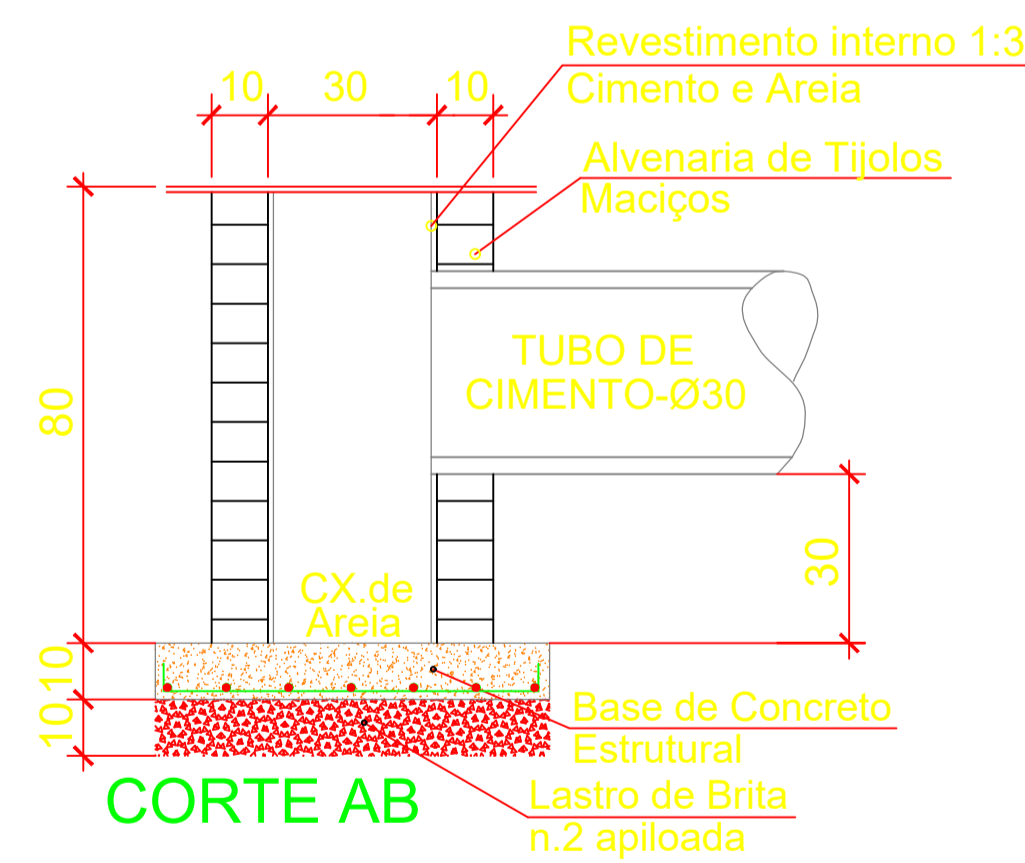

CORTE AB

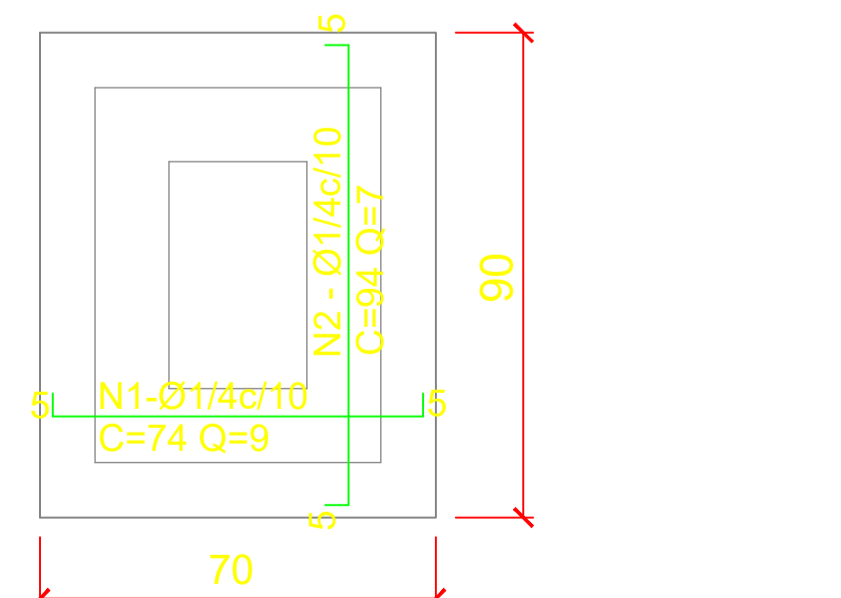

DETALHE LAJE DO FUNDO CONCRETO ESTRUTURAL

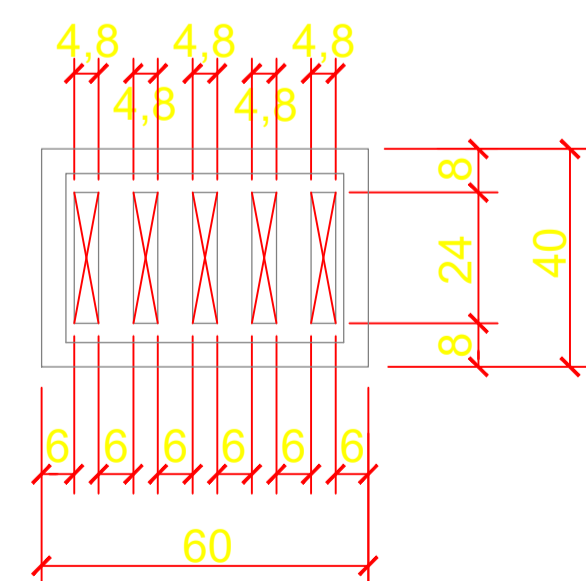

N1-2Ø3/8
C=55

N2-6Ø3/8
C=35

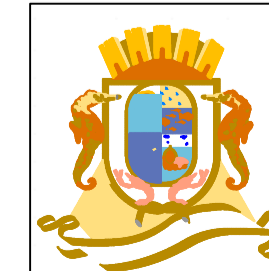

PREFEITURA MUNICIPAL DE BOMBINHAS
SECRETARIA DE PLANEJAMENTO E REGULACAO URBANA

OBRA: PAVIMENTACAO E DRENAGEM PLUVIAL DA RUA JEQUITIBA
ENDEREÇO: BAIRRO DE CANTO GRANDE - BOMBINHAS
CONTEUDO DE PRANCHA: DETALHES

PAULO HENRIQUE DALAGO MULLER
PREFEITO MUNICIPAL

ROBERTO XAVIER KALFELTZ
SECRETARIO DE PLANEJAMENTO

AMAURE F. RAMOS NETO
RESPONSÁVEL TÉCNICO

ARQUIVO
2021

DATA
15/01/2021

PROJETO
Bruno Oliveira
Amauri Ramos
Gabriel Reiser

ESCALA: PRANCHA
INDICADA 04/04