

PLANTA BAIXA - PAVIMENTO INFERIOR

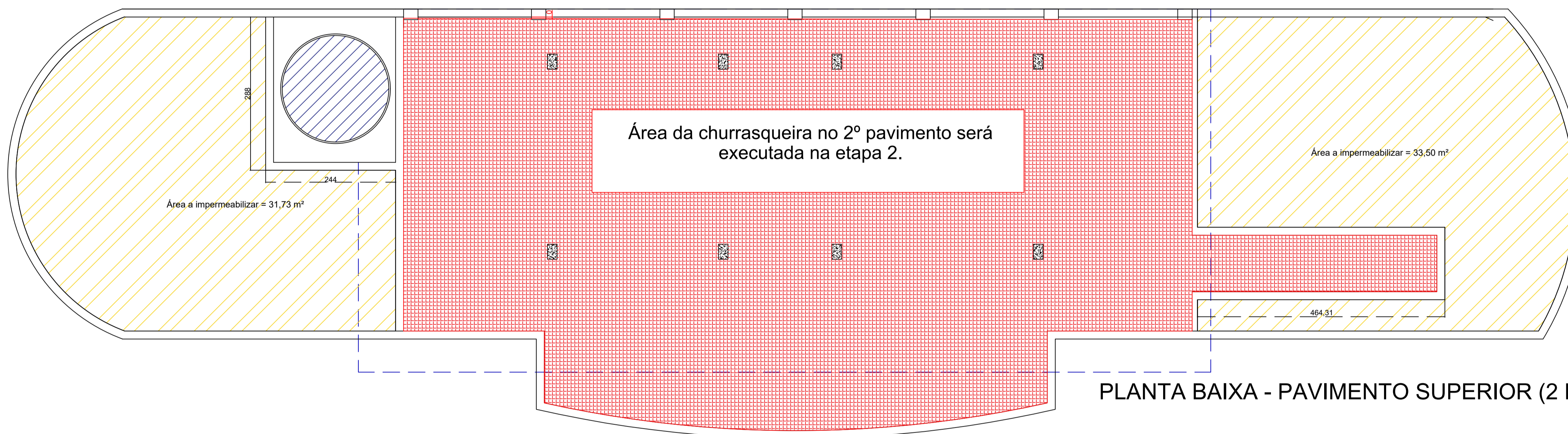

PLANTA BAIXA - PAVIMENTO SUPERIOR (2 ETAPA)

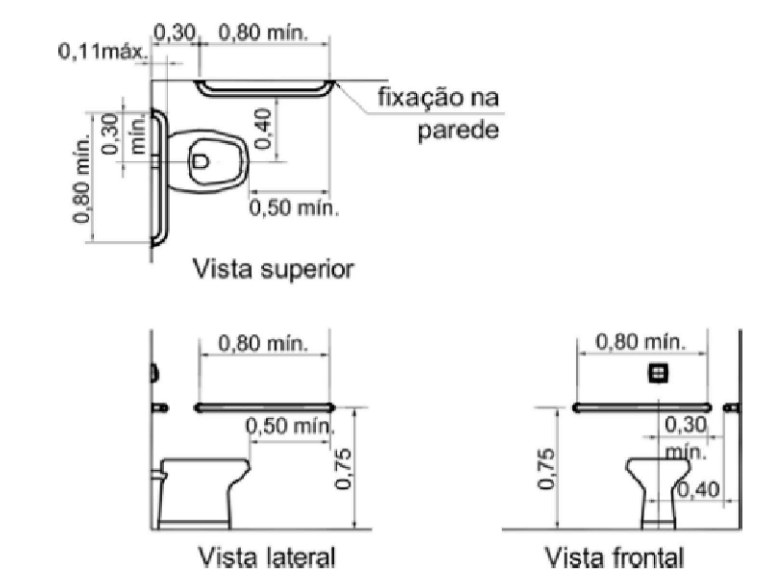
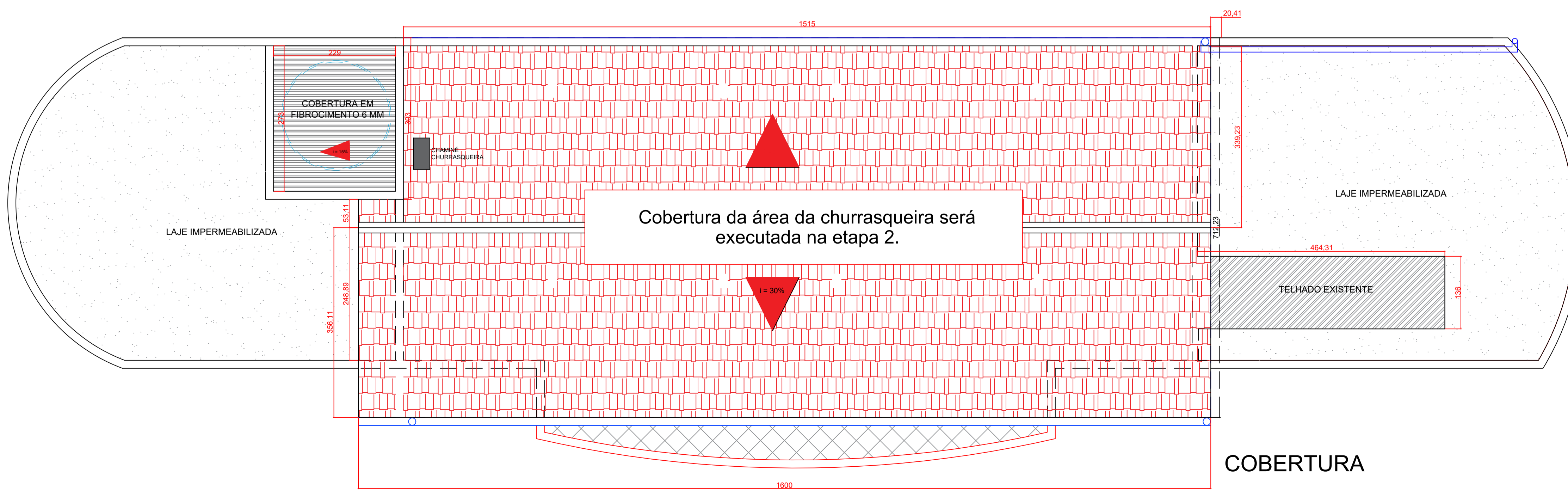

COBERTURA